

Protocol for using the dry Frisbee (with foam insert) dust deposit gauge

1 Description of the gauge

The Frisbee-shaped collecting bowl should be made of anodized, spun aluminium and have the dimensions shown in Fig. 1. It should be supported with the opening 1.7 m above ground level and have an opaque drain pipe leading from the stem down to a rainwater collecting bottle¹ on the ground. For collection periods of one month the capacity of the bottle should be at least 5 litres. The collecting bowl should be lined with a 10-mm thick, 240-mm diameter, disc of black, open-celled (10 pores per inch) polyester foam. The gauge should incorporate a bird-strike preventor in the form of a ring of fine (1-mm thick) plastic fishing line (left slightly slack) supported 5 cm above the collecting bowl on six stainless steel struts (Fig. 2). The diameter of the ring should be slightly greater than that of the collecting bowl so that the latter can be taken out and replaced at the end of each collection period.

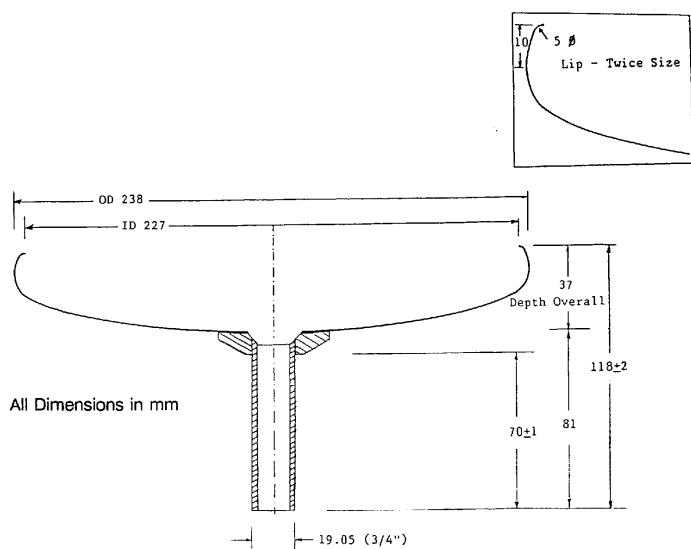

Figure 1 Cross section through the collecting bowl of the Frisbee type of dust deposit gauge (from Hall, Upton & Marsland, 1993)

2 Choosing a site

Make sure the gauge is sited on a horizontal surface at a secure location well away from obstructions such as buildings, trees and over-head wires (on which birds might perch). There should be no large object within 5 metres of the gauge and, as a general

rule, the top of any obstructions should subtend less than a 30° angle with the horizontal at the sampling point.

3 Processing gauges in the field

3.1 At the end of each collection period (usually one month) remove the Frisbee (with foam disc still in place) and fit the perspex cover over it secured with adhesive tape. Label it to show the site location and date of retrieval.

3.2 Pour 100 ml of distilled (or deionized) water into the top of the connecting pipe and attach a clean Frisbee containing a clean foam disc².

3.3 Label and remove the collecting bottle and replace it with a clean one containing a suitable biocide³.

3.4 Return the Frisbee and collecting bottle to the laboratory.

4 Recovering the dust

4.1 Pre-weigh (to the nearest 0.1 mg) a 9-cm diameter Whatman GF/A glass microfibre filter after drying it on a watch glass (or glass Petri dish) in an oven for 1 hour at 80°C and equilibrating for 2 hours in a desiccator. (Use tweezers when picking up filters and do not place filters directly onto unclean surfaces).



Figure 2 Position of bird strike preventor and supporting struts

¹ The collecting bottle should be darkened with black adhesive tape to suppress algal growth.

² Foam discs should be renewed annually.

³ A biocide such as 2-methoxyethanol (200 ml of a 10% solution) should be added (whilst wearing suitable gloves and eye protection) to inhibit microbial growth.

4.2 Filter the contents of the collecting bottle, under suction, using a Whatman 3-piece funnel⁴ (or similar) leading into a 1 litre Buchner flask. A large (20-cm diameter) funnel should be supported above the reservoir section and a sieve (e.g. a tea strainer), with a 1-mm sized mesh, placed between them to remove any larger pieces of extraneous material. The volume of water collected may be recorded to give a measure of precipitation. Use a wash bottle (containing distilled or deionized water) and a “rubber policeman” (a nylon or perspex rod with a rubber teat on the end) to loosen and rinse off any deposits inside the collecting bottle and pass washings through the filter.

4.3 Remove the perspex cover from the Frisbee, inspect the foam disc and remove (and make a note of) any leaves, bird droppings or other extraneous material on its surface.

4.4 Wearing clean plastic gloves (e.g. disposable latex type), thoroughly rinse the foam disc in 1 litre of distilled (or deionized) water in a clean container (e.g. a 2 litre beaker). Pass this water through the filter.

4.5 With the aid of the wash bottle and “rubber policeman” rinse off all the dust on the Frisbee and pass washings through the filter.

[**NB.** If a spare Frisbee and foam disc are not available the dust may be rinsed from them in the field (with the Frisbee *in situ*), washings from both being added to the collecting bottle before its removal .]

4.6 Make a note of, and weigh separately, any material retained on the sieve which has originated from domestic or industrial processes.

4.7 Re-weigh the filter after drying and equilibrating as before.

4.8 Thoroughly clean all apparatus between samples to avoid cross-contamination.

5 Determining the rate of dust deposition.

Calculate the mean rate of dust deposition (undissolved solids) as:

$$\frac{(W2-W1) \times 24.7}{T} \text{ mg m}^2 \text{ day}^{-1}$$

where W1 = initial dry weight of filter (in mg)

W2 = final dry weight of filter plus dust (in mg)

and T = length of exposure period (in days)

End piece

SEIY has been involved in the development of an improved design of ambient dust deposit gauge (in collaboration with Warren Spring Laboratory, Stevenage, UK and Selby District Council, North Yorkshire, UK.) since 1987. The collecting bowl of this gauge was based on an inverted Frisbee shape and several different versions of it been evaluated in the field during

dust monitoring programmes near coal-fired power stations in North Yorkshire, UK. (Vallack and Chadwick, 1992, 1993; Vallack, 1995). The version of the Frisbee gauge described in this protocol performed with an efficiency approximately 36% greater than that of the current British Standard deposit gauge (Vallack, 1995). Guideline values for dustfall based on ‘likelihood of complaint’, appropriate for results from the Frisbee (with foam insert) dust deposit gauges, are suggested by Vallack and Shillito (1998). In consultation with SEIY, the Frisbee (with foam insert) dust deposit gauge has been developed commercially⁵ and is available at about half the cost of the British Standard dust deposit gauge.

References

- Hall D. J., Upton S. L. and Marsland G. W. (1993) Improvements in dust gauge design. In *Measurements of Airborne Pollutants* (edited by S. Couling), Chap. 11. Butterworth, Heinemann.
- Vallack H. W. (1995) A field evaluation of Frisbee-type dust deposit gauges. *Atmospheric Environment* **29**, 1465-1469.
- Vallack H. W. and Chadwick M. J. (1992) A field comparison of dust deposit gauge performance at two sites in Yorkshire, 1987-1989. *Atmospheric Environment* **26A**, 1445-1451.
- Vallack H. W. and Chadwick M. J. (1993) Monitoring airborne dust in a high density coal-fired power station region in North Yorkshire. *Environmental Pollution* **80**, 177-183.
- Vallack H.W. and Shillito D.E. (1998) Suggested guidelines for deposited ambient dust. *Atmospheric Environment* **32**, 2737-2744.

Stockholm Environment Institute-York (SEI-Y)
Biology Department, University of York
York YO10 5YW, UK
Tel.: +44 1904 432897 or +46 8 412 1400
Fax.: +44 1904 432898
Email: hww1@york.ac.uk
Website: www.seiy.org

H. W. Vallack (Stockholm Environment Institute at York) February 1995

⁵ This gauge is manufactured by Mr Ian Hanby, 4 Elston Hall, Elston, Newark NG23 5NP, UK. Tel. +44 1636 525603; Fax +44 1636 525631; email: ian@hanby.co.uk; website: www.hanby.co.uk/